

INSTRUCTIONS FOR INSTALLING A THUMPER IN A PRE-GROUND COFFEE CANISTER

CHECK THE PARTS RECEIVED IN THE KIT WITH THE PARTS LIST IN THESE INSTRUCTIONS. IF ANY PARTS ARE MISSING, CONTACT NATIONAL VENDORS' PARTS DEPARTMENT

Read these instructions carefully before installing the kit.
Keep these instructions for part numbers and for future reference.

This kit contains the following.

| INDEX | PART NUMBER | DESCRIPTION | QUANTITY |
|-------|-------------|---------------------------|----------|
| 1 | 6237001 | Mixing wheel | 1 |
| 2 | 6237004 | Thumper spring | 1 |
| 3 | 6237009 | Template | 1 |
| 4 | 6234295 | Screw | 5 |
| 5 | 3106215 | Nut | 5 |
| 6 | 6237116 | Washer | 1 |
| | 6237010 | Installation instructions | 1 |

INSTALL THE THUMPER KIT ACCORDING TO THE FOLLOWING INSTRUCTIONS:

1. Remove the pre-ground coffee canister and empty it.
2. See figure 1. From the inside of the canister, push out the 6 plastic clips. Separate the canister top from the inside of the canister, push out the 6 plastic clips. Separate the canister top from the canister bottom. Save the plastic clips for later.
3. See figure 2. From the inside of the canister, push out the plastic clip that secures the old Thumper spring. Remove and discard the spring.
4. See figure 3. Spread the canister sides and remove the old mixing wheel. Discard the mixing wheel.
5. See figure 4. Spread the canister sides and install the new mixing wheel (1).
6. See figure 5. Install the new thumper spring (2) and secure it with the plastic clip you removed previously.
7. Cut out the template (3) and fold it as shown on the template sheet.
8. See figure 6. Hold the template against the canister top and drill a 0.19" hole in the location shown.

NOTE

When assembling the canister, plastic clips **MUST** be used on the left side of the right-hand canister, or on the right side of the left-hand canister.

9. See figure 7. Assemble the canister top to the canister bottom. Secure the canister top with two plastic clips you removed previously, and four screws (4) and nuts (5) as shown.
10. Secure the Thumper spring to the hole you drilled of the Canister top with one screw (4), one washer (6), and one nut (5).
11. Sanitize the canister, taking care to remove all drilling debris.
12. Replace the canister in the machine and refill with pre-ground coffee.

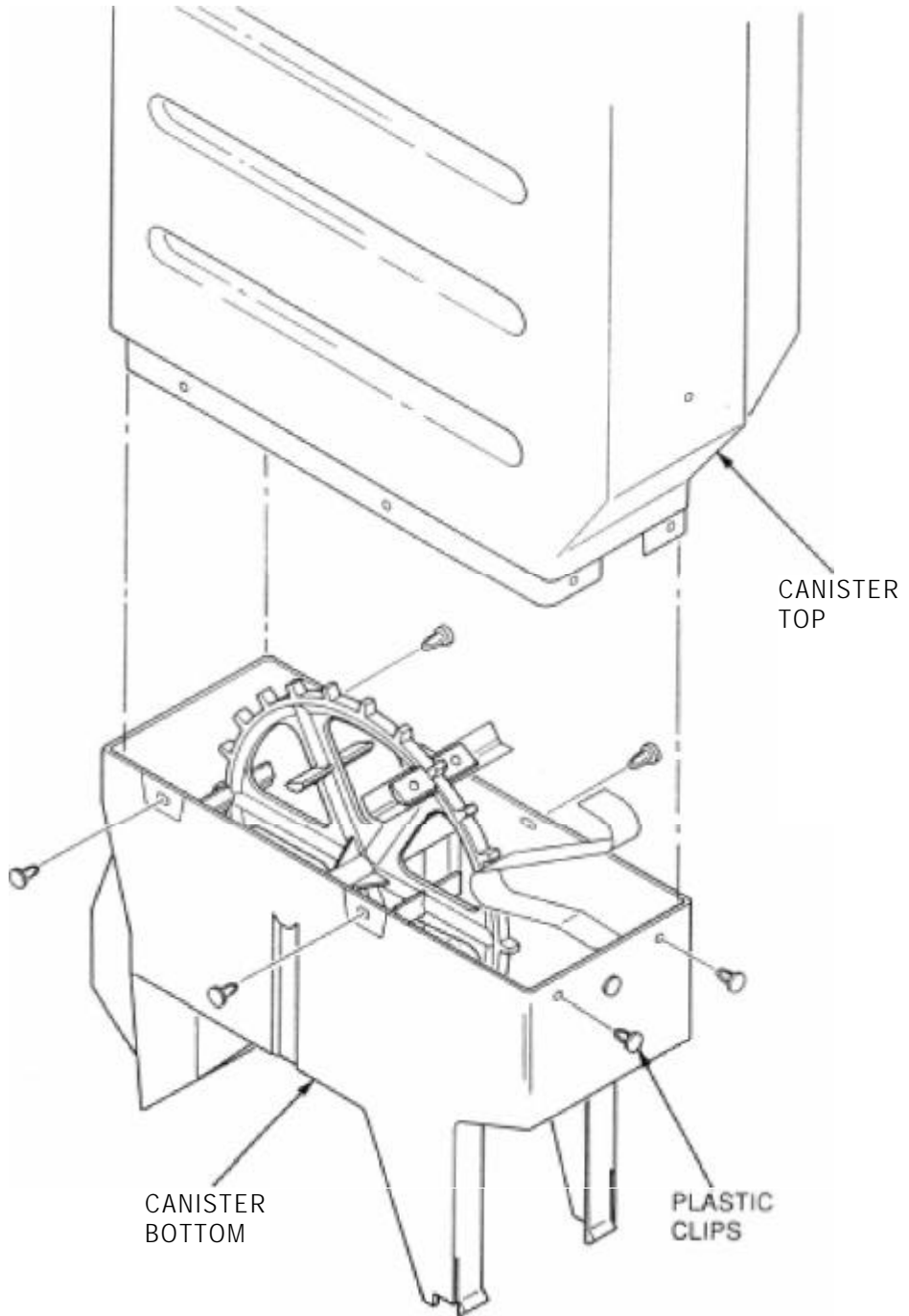

Figure 1.

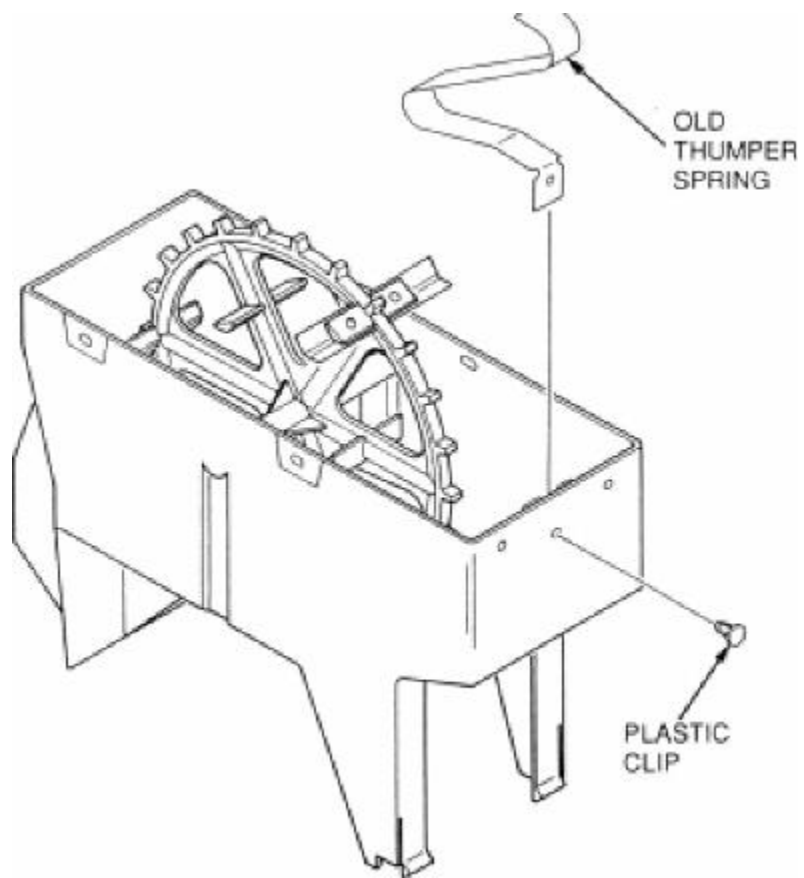

Figure 2

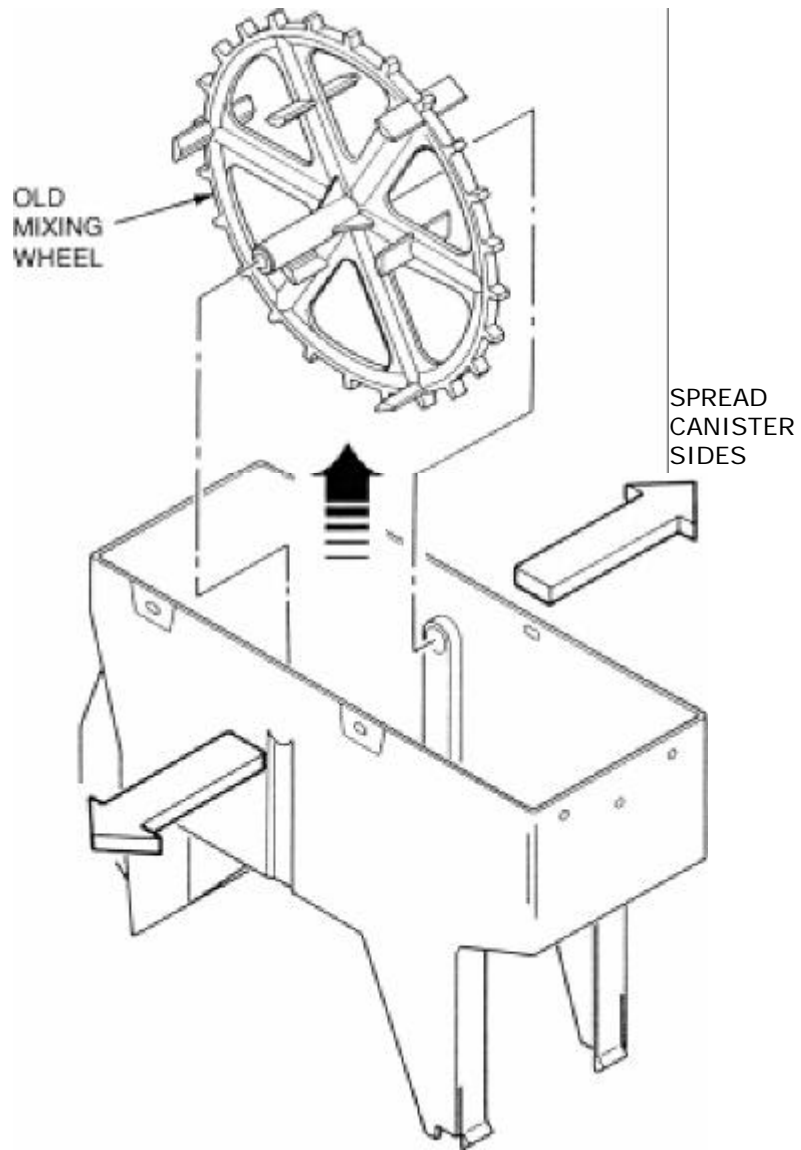

Figure 3.

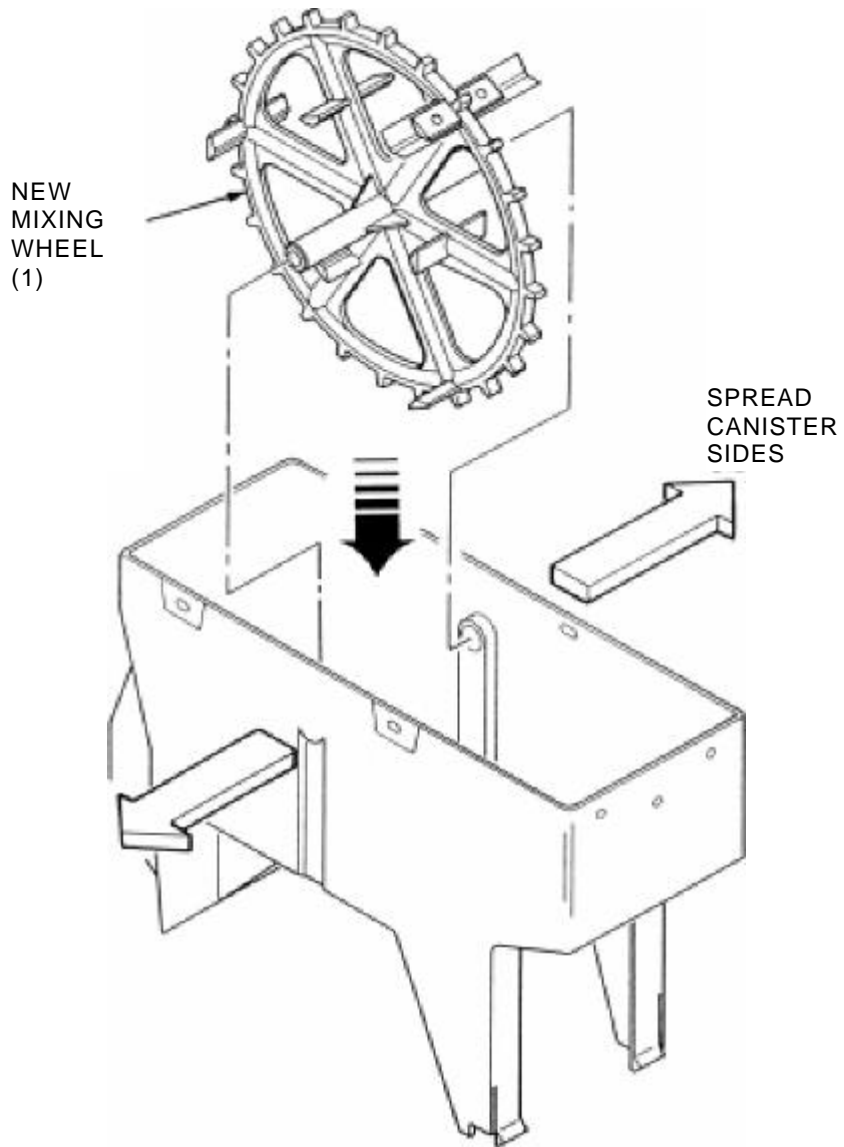

Figure 4.

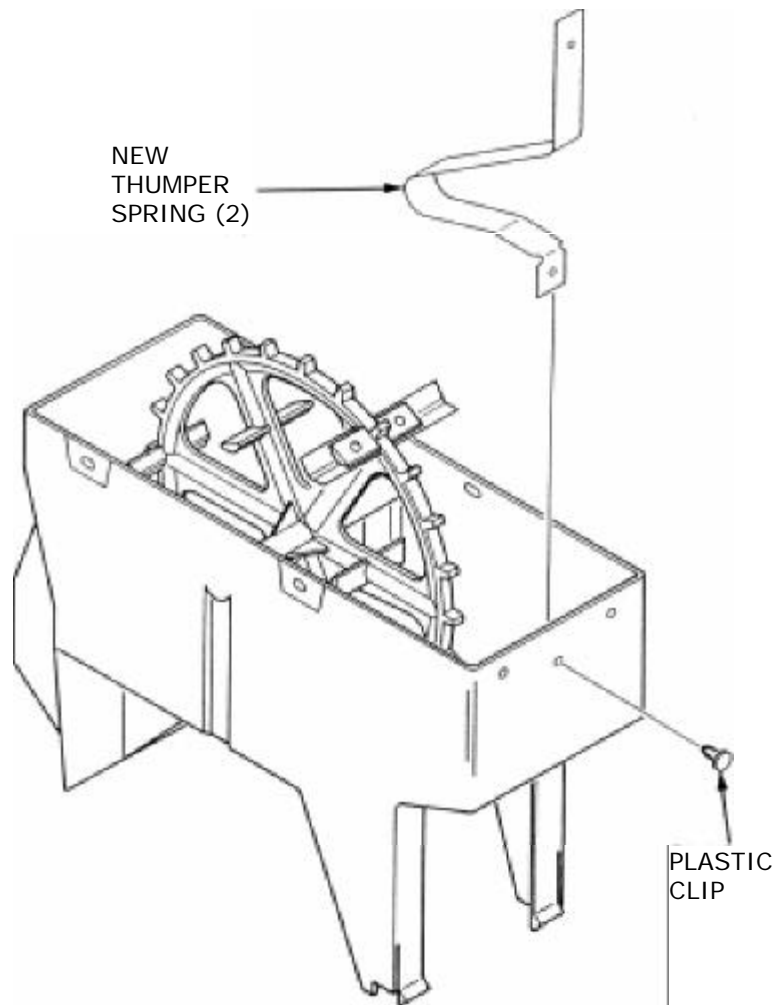

Figure 5.

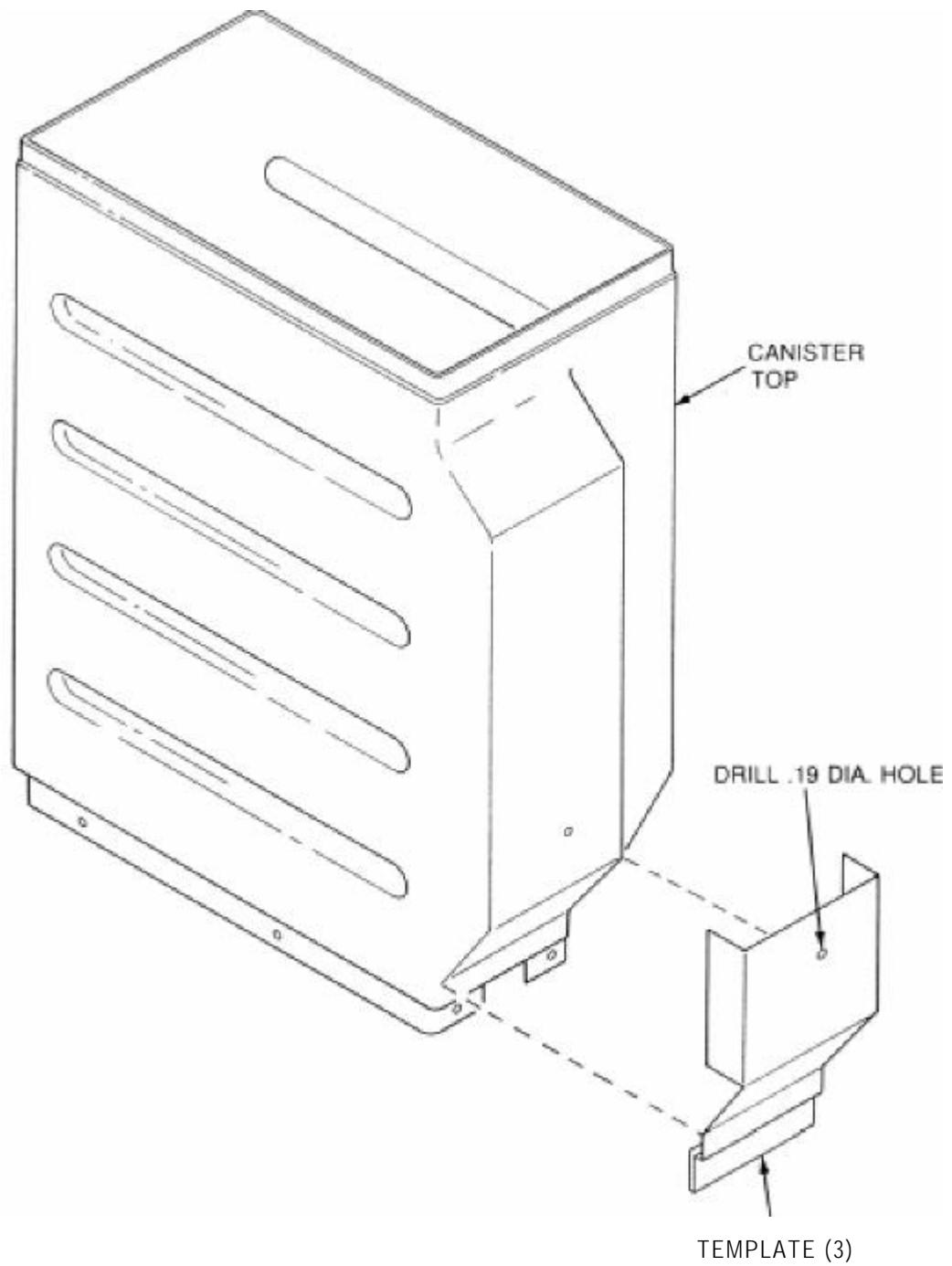
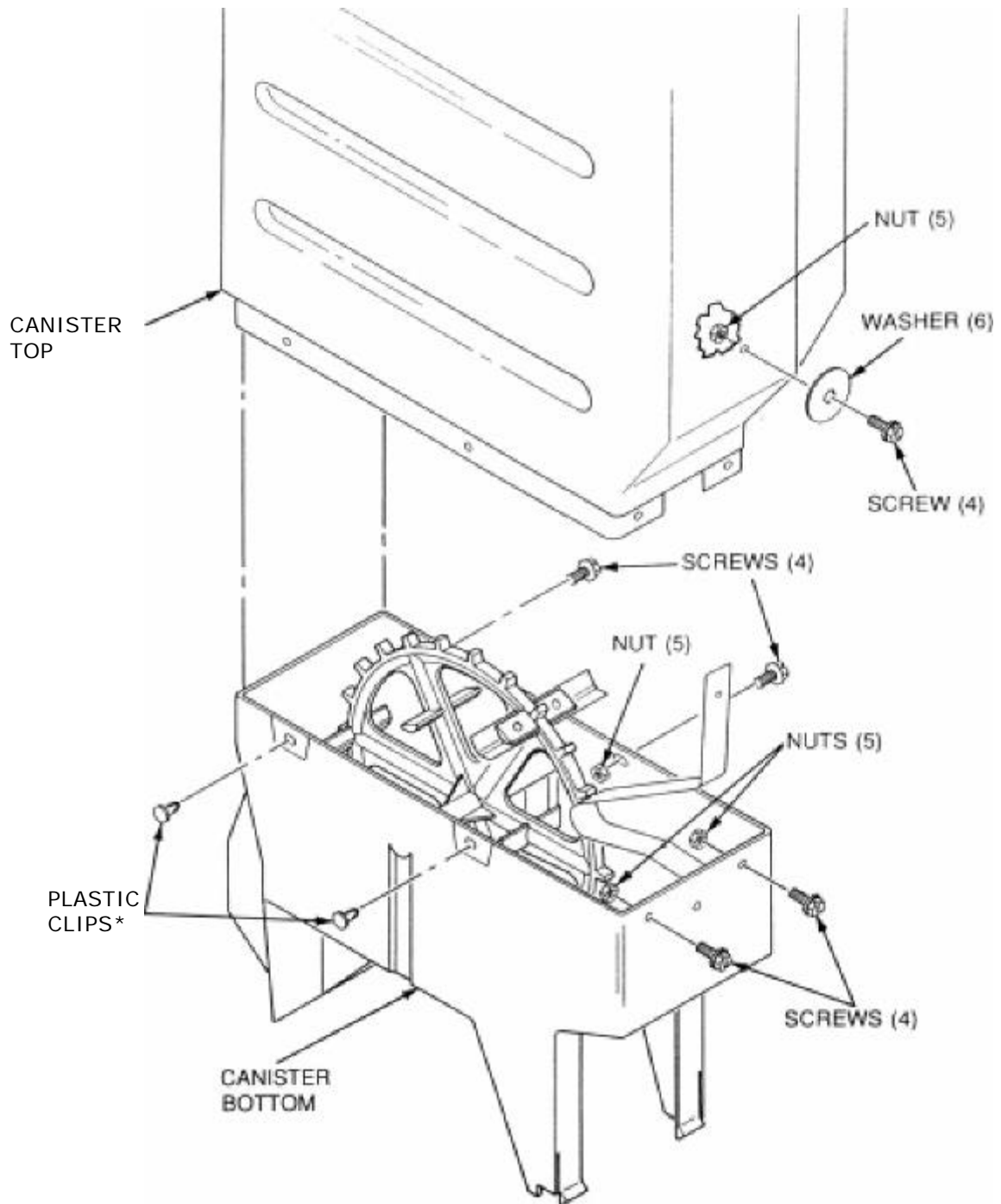

Figure 6.



* NOTE: SEE TEXT FOR PROPER USAGE OF PLASTIC CLIPS AND SCREWS

Figure 7.